

TECHNICAL DOCUMENT

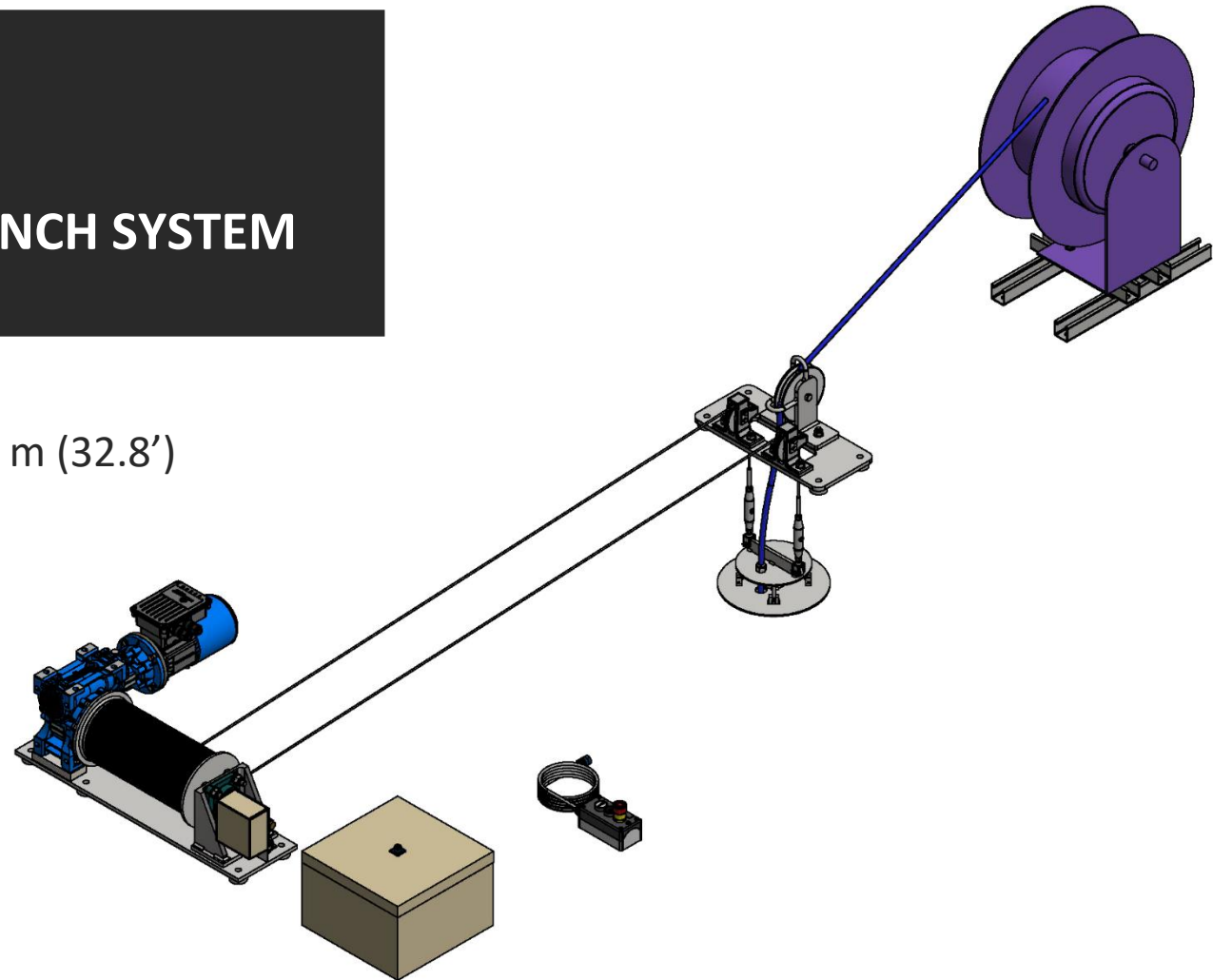

RLT-250 TWIN ROPE ELECTRIC WINCH SYSTEM

MAX LOAD: 250 kg (550 lbs)
MAX LOWERING DISTANCE: 10 m (32.8')
SKU: 872-000076



Contents

Contents.....	2
System overview	3
Min/max layout distances.....	4
Electric winch dimensions.....	5
Drop pulley assembly dimensions	6
Automatic cable retraction reel dimensions.....	7
Load attachment detail	8
Mounting dimensions	9
System loadings	10
Winch system technical specifications	11
Wired remote control technical specifications.....	12
Wireless radio remote system technical specifications.....	13

System overview

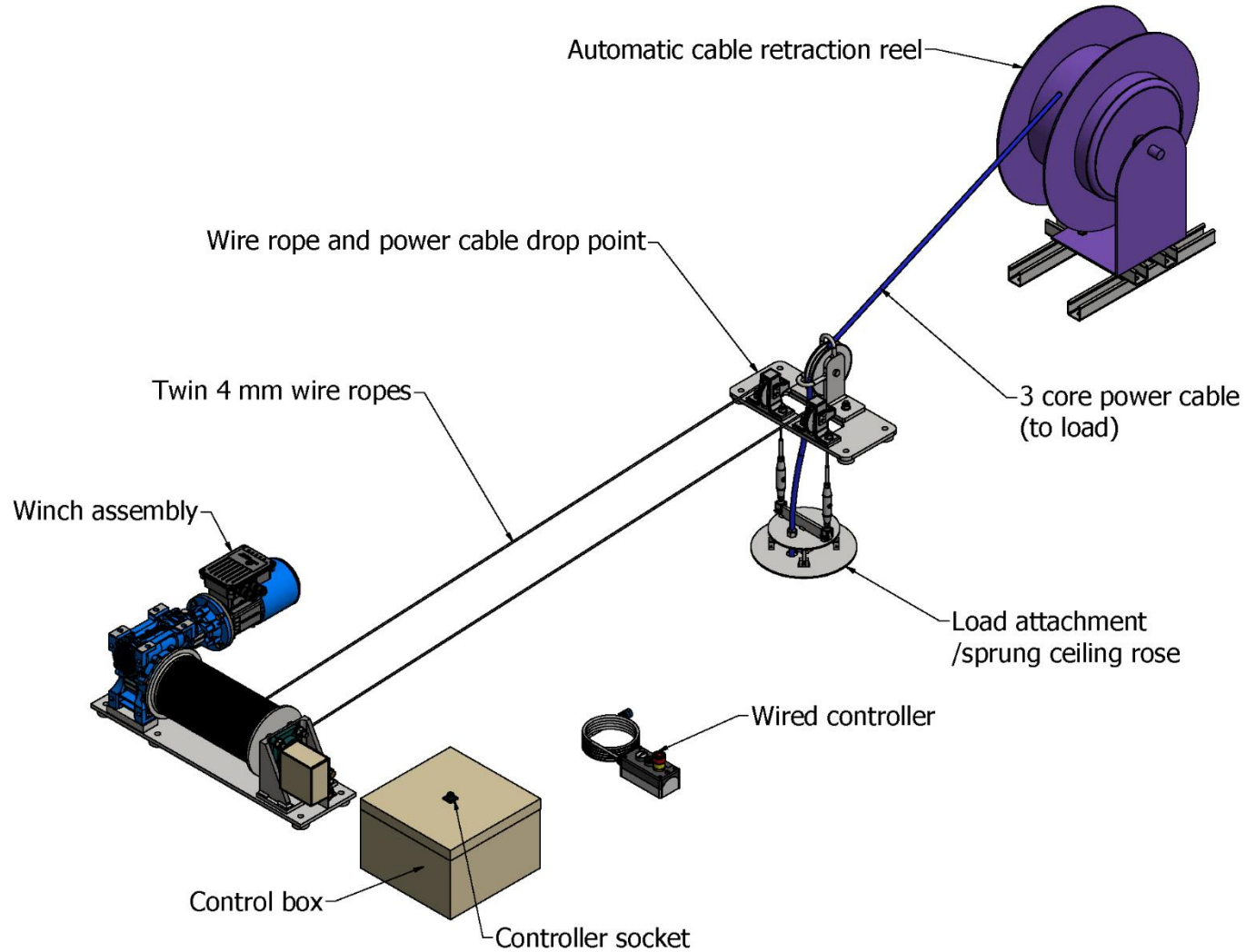

Min/max layout distances

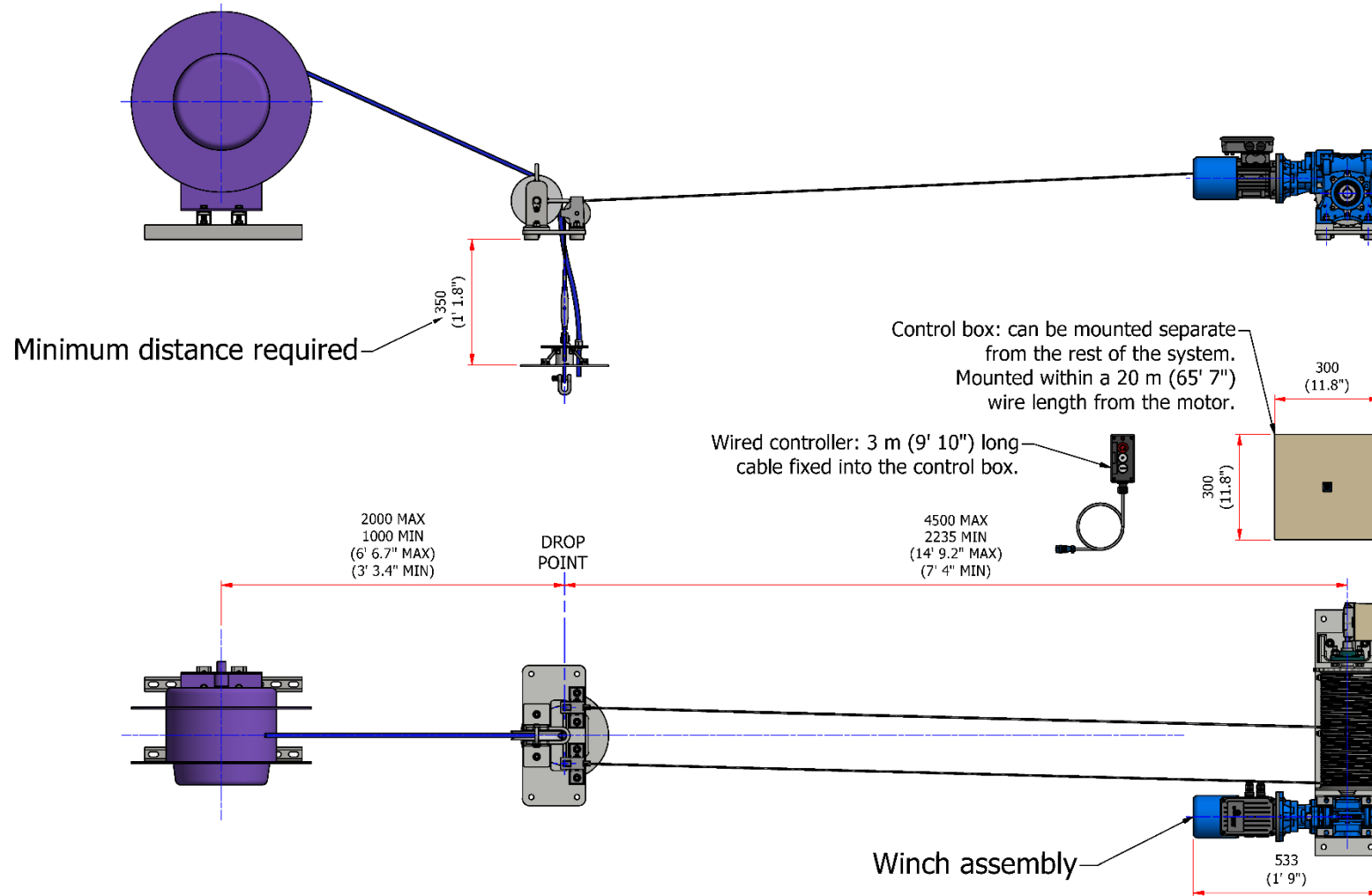

Electric winch dimensions

Mass: 53 kg (167 lbs)

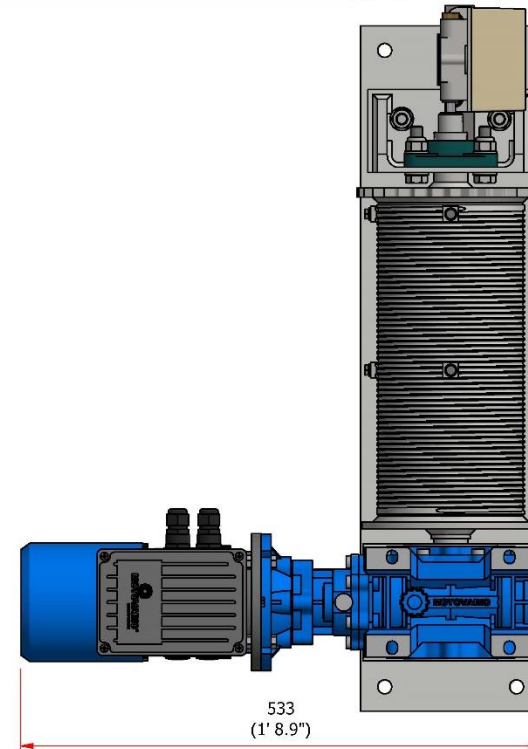
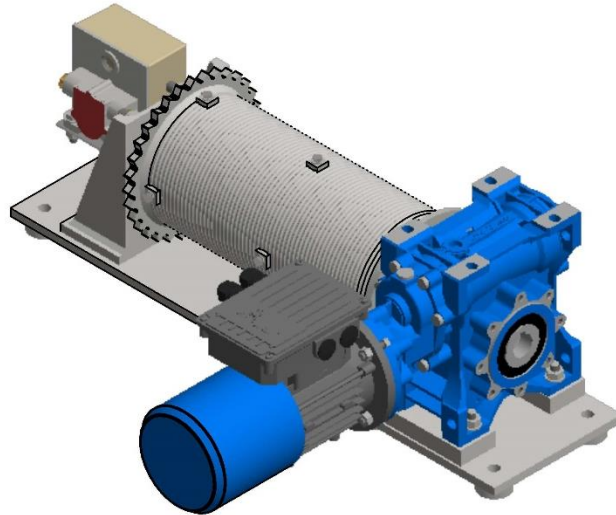
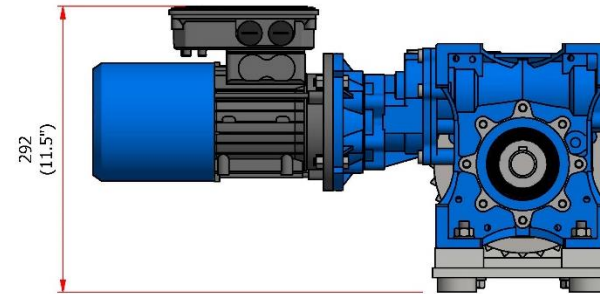
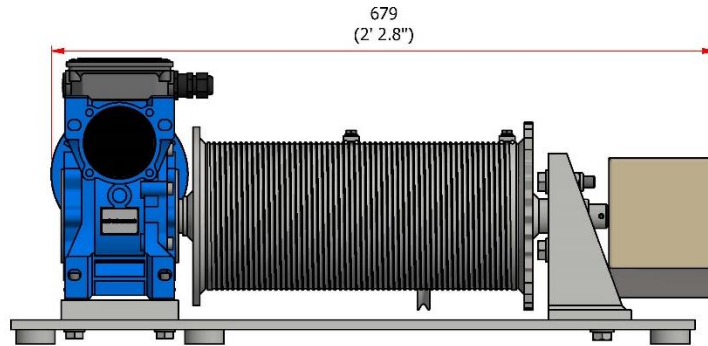

Drop pulley assembly dimensions

Mass: 10 kg (22 lbs)

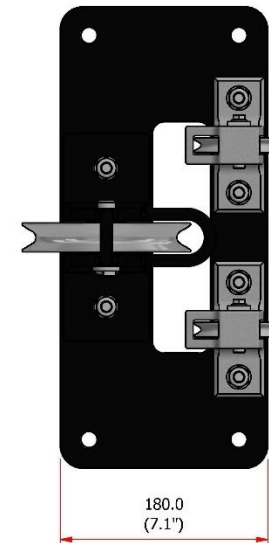
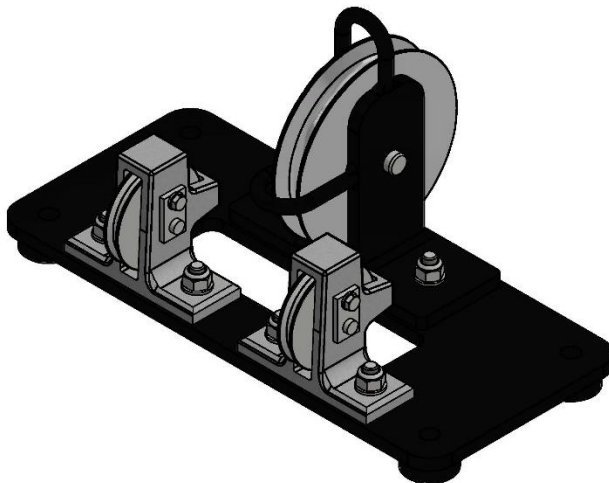
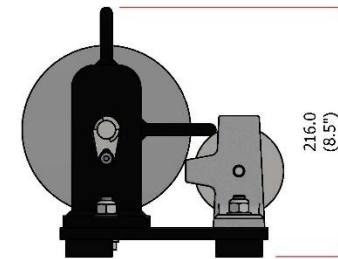
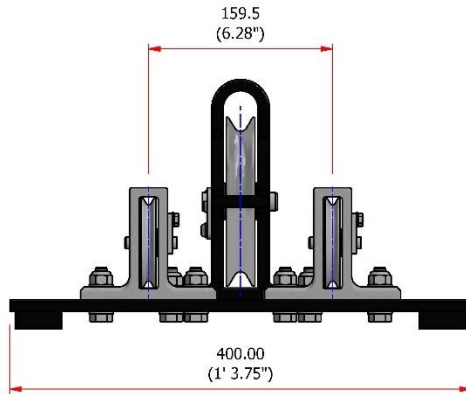

Automatic cable retraction reel dimensions

Mass: 46 kg (102 lbs)

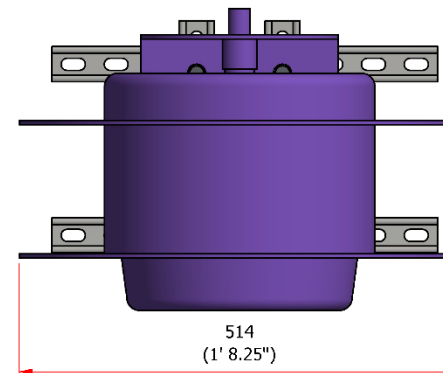
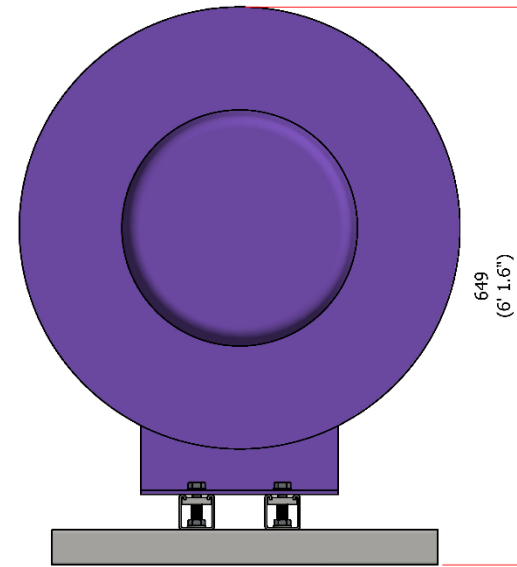
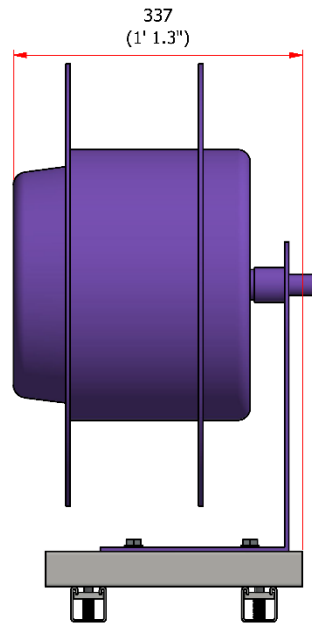

Load attachment detail

Mass: 11 kg (25 lbs)

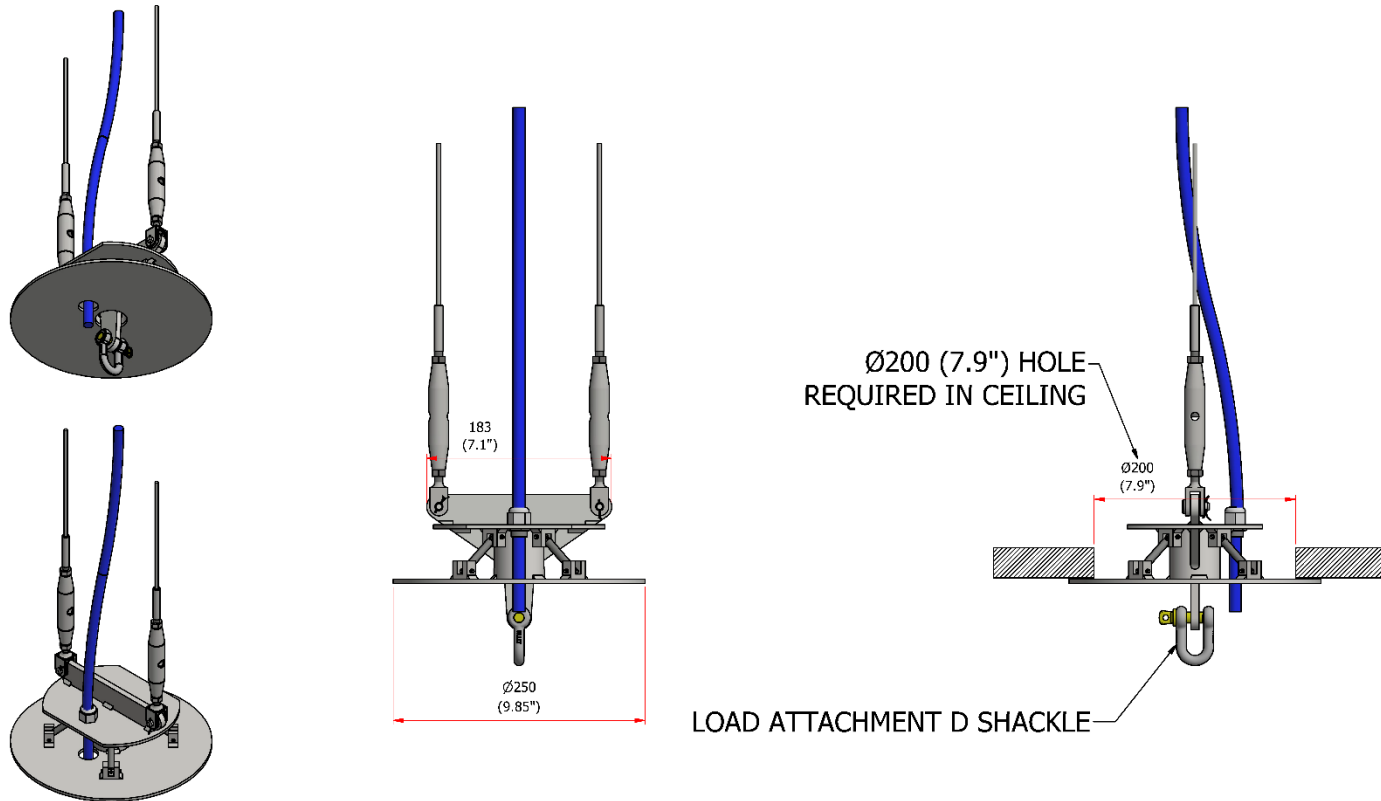

Visible plate undercoat painted to allow easy customisation.
There is the opportunity to mount decorative ceiling rose
onto this plate by drilling and tapping.
Permissible maximum additional mass of 5 kg.

Mounting dimensions

Cable Reel Mounting

4 x M10 fasteners

Cable Reel Mass: 46 kg (102 lbs)

Pulley Assembly Mounting

4 x M12 fasteners

Pulley Assembly Mass: 10 kg (22 lbs)

Winch Assembly Mounting

6 x M12 fasteners

Winch Assembly Mass: 53 kg (167 lbs)

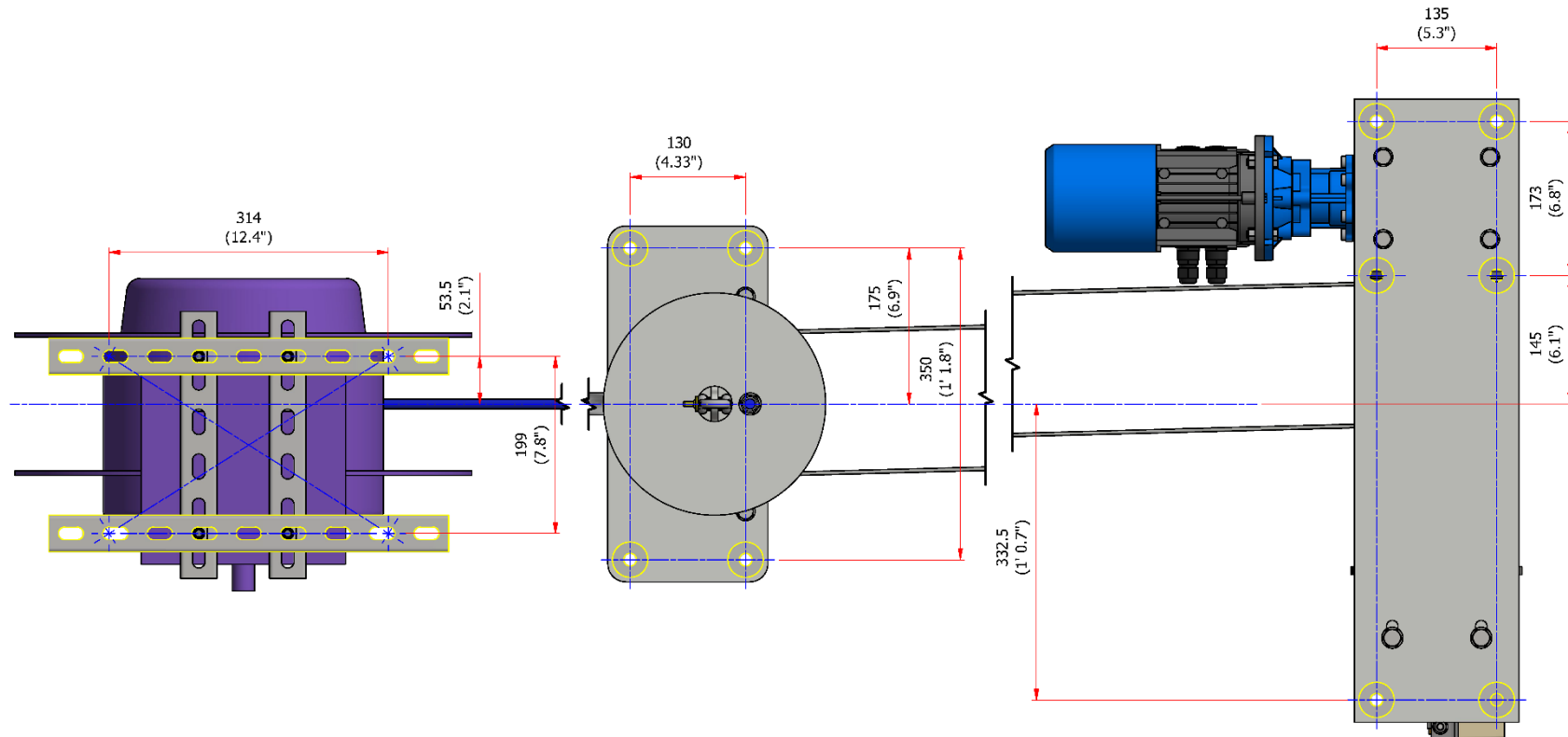

System loadings

Maximum Loading Produced

Includes: proof operation loading of 25% over SWL and self weight

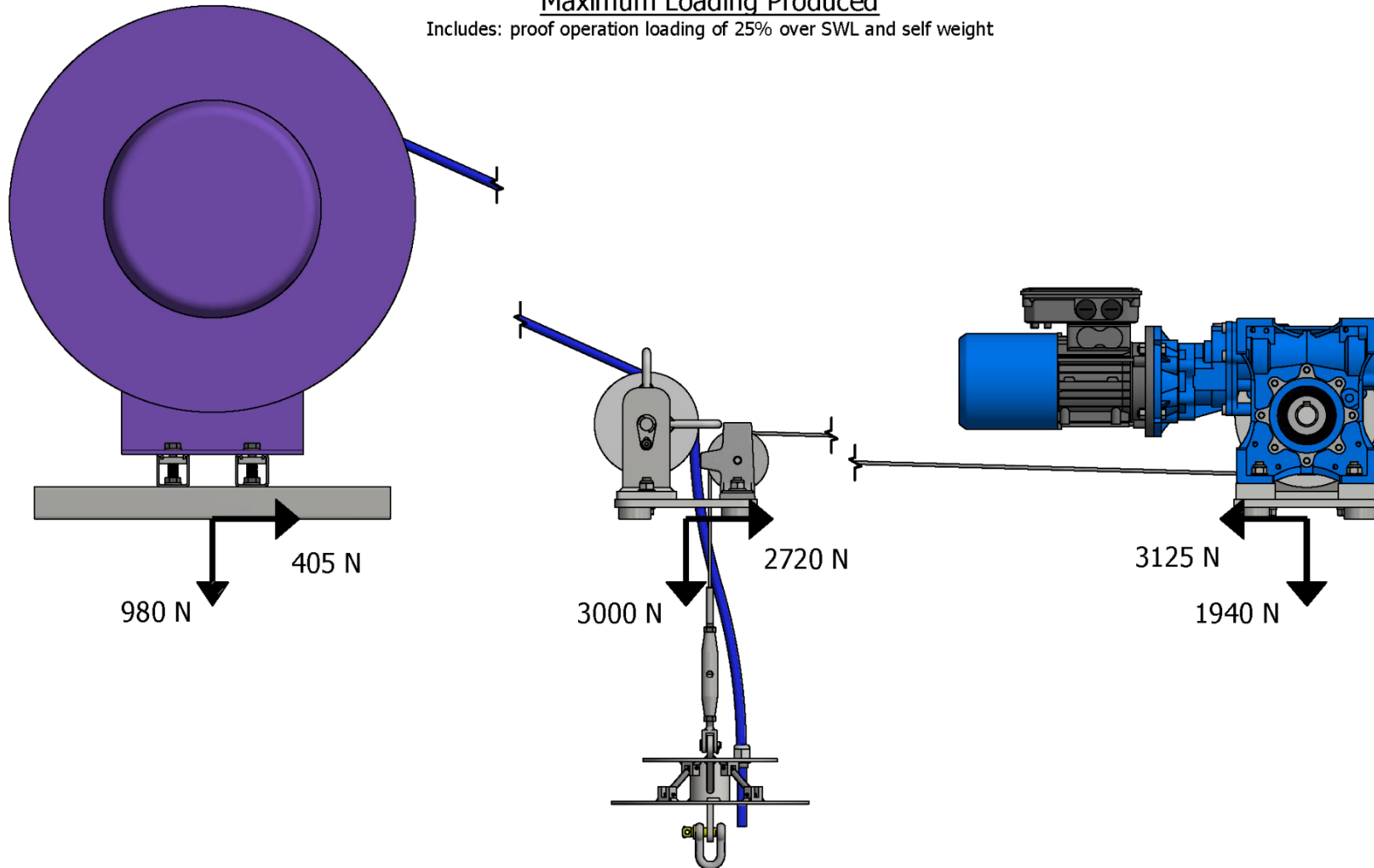

Winch system technical specifications

SKU	872-000076
Maximum load	250 kg (550 lbs)
Maximum lowering distance	10 m (32' 8")
Maximum power feed to load	3-core, 15 A per core
Winch system power requirements	13 A 240 V single phase, 50 Hz (USA – 13 A, 120 V single phase, 60 Hz)
Shipping dimensions	870 x 950 x 660 mm (34.3" x 37.4" x 23")
Shipping weight	187 kg (413 lbs)
No of automatic stop positions	2
Raising/lowering speed	1.2 m/min (3.3 ft/min)
Running noise	Lift operating when loaded below 46 dB(A)
Running mode	Soft start/stop
Installation environment	Internal use only
Control type	Wired remote control (standard), radio wireless system (optional)
Conformity	The Supply of Machinery (Safety) Regulations 1998 BS 7906-1 Category B BS EN ISO 12100:2010 Safety of Machinery – General principles for design – Risk assessment and risk reduction 2014/30/EU Electromagnetic Compatibility Directive 2014/35/EU Low Voltage Directive Lifting Operations and Lifting Equipment Regulations 1998

Wired remote control technical specifications

Cable length	3 m (9' 10")
Protection class	IP65
Housing material	Polycarbonate
Functions	2 – Hold to run + E-stop
Dimensions	106 x 68 x 53 mm (4.2" x 2.7" x 2.1")
Mass	0.4 kg (0.9 lbs)



Wireless radio remote system technical specifications

(must be specified as optional extra)

Progrip handset

Power supply	4.5 V (3x AA Batteries)
Frequency	433.05-434.79 MHz
Antenna	Internal
Range	Up to 100 m (328')
Protection class	IP65
Housing material	ABS
Functions	2 – Hold to run (with Enable)
Dimensions	160 x 78 x 35 mm (6.2" x 3" x 1.4")
Weight	240 g (8.5 oz)

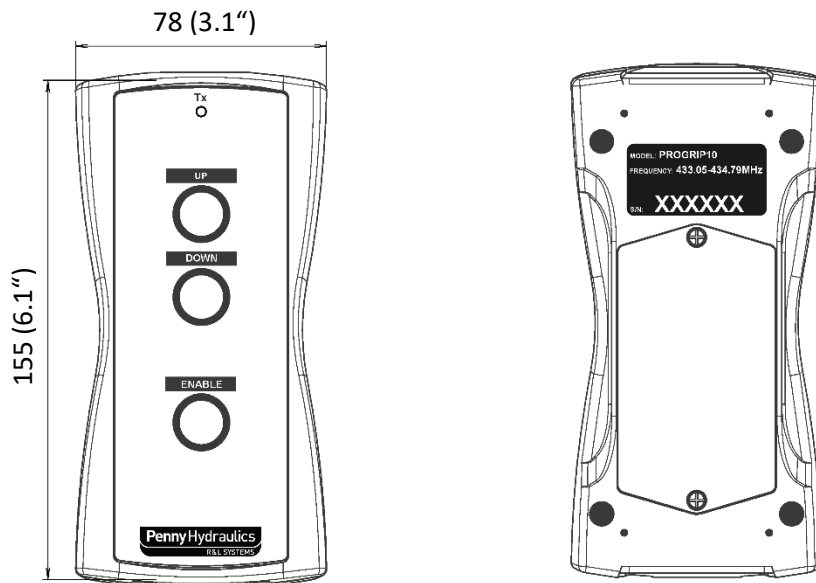

Ultrabeam DC4 receiver

Power supply	12-28 VDC
Frequency	433.05-434.79 MHz
Antenna	External
Protection class	IP65
Housing material	ABS (UL94-HB)
Dimensions	145 x 91 x 55 mm (5.7" x 3.5" x 2.2")
Mounting	4x clearance holes for M4 bolts/4mm screws
Rated load	10 A at 24 VDC / 250 VAC

