

# GridLift range

Operating & maintenance instructions



# Welcome

Thank you for purchasing a Penny Hydraulics crane.

All our products are designed, developed and manufactured to stringent quality and safety standards at our purpose built UK facility.

We understand that you need the peace-of-mind of a planned maintenance programme in order to achieve full compliance with European legislation, so we offer a choice of extremely cost-effective service packages which include examination and testing - more details can be found on the inside back cover of this booklet. We can also offer additional support in the form of our specialist training services - please contact us for more details.

## Accessories

We supply a wide range of lifting accessories including slings, shackles and special attachments such as kerb grabs, barrel slings and dumpy bag lifters.

You can also buy replacement parts for your crane direct from our website - <https://shop.pennyhydraulics.com>

Our online parts shop stocks everything from wire ropes and solenoids to complete boom assemblies, winch motors and remote controls.



# GridLift – GL250KJ

## Operating and Maintenance Instructions



Station Road  
Clowne  
Chesterfield  
Derbyshire  
S43 4AB

Tel: 01246 811475

Fax: 01246 810403

E-mail: [sales@pennyhydraulics.com](mailto:sales@pennyhydraulics.com)

Website: [www.pennyhydraulics.com](http://www.pennyhydraulics.com)

## Safety Warning

**In the interest of safety all personnel involved in the operation of the GL250KJ must read and understand this operation manual. If they do not then they must not operate the equipment.**



- Do not use the GL250KJ if it is not supported with valid documentation recording a Thorough Examination being carried out by a Competent Person within the last 12 months.
- The GL250KJ must not be used for man riding.
- The GL250KJ should be inspected every six months and serviced annually by a competent person. See “Maintenance” in this manual for full Statutory responsibilities.
- The GL250KJ must not be overloaded. Refer to the safe working load signs attached to the equipment.
- The GL250KJ must only be operated by trained and competent personnel. Training is offered by Penny Hydraulics and a training register is included at the back of this manual.
- Use only correct and certified lifting attachments. Lifting attachments must be formally certified by Thorough Examination every 6 months.
- Use only genuine parts and accessories.
- During operation of the GL250KJ, access to the area should be restricted to those personnel essential to the operation only.
- Do not leave any load suspended between lifting / lowering operations.
- All safety notices must be adhered to at all times.
- Never interfere with the unit. It should run smoothly at all times, if in doubt call the HELPLINE telephone number 01246 811475.
- Keep the GL250KJ properly maintained by a competent person. See the “Maintenance” section in this manual.
- Do not adjust or interfere with any factory settings.
- Isolate, immobilize and lock-off the equipment before commencing any maintenance routine.
- Ensure any site specific barriers, guards and fencing are securely in place before commencing any work.
- Do not modify or re-install this machine without seeking guidance from Penny Hydraulics Ltd.

# CONTENTS

Page

2. Safety Warning
3. Contents
4. Introduction
5. Operation
6. Fault Finding
7. Warranty Policy
8. Maintenance, Recommended Spares, Recommended Lubricants
9. Statutory Obligations
11. Service Contract
12. Technical Data
14. Declaration of Conformity
15. Signs
16. Parts List
17. Electrical Schematic
18. Training Register
19. Work Record

## Introduction

Thank you for purchasing a Penny Hydraulics **GridLift** Knuckle Joint crane.

The **GridLift** GL250KJ is a vehicle mounted lift designed and manufactured at our factory in Clowne, Chesterfield to safely lift and position loads of up to 250kg.

The lift is operated remotely from a hand held pendant control with all functions being protected by inbuilt overload features and is powered by the vehicle battery.

These operating instructions tell you what you need to know about its operation along with guidance on safety and general care, please study them carefully.





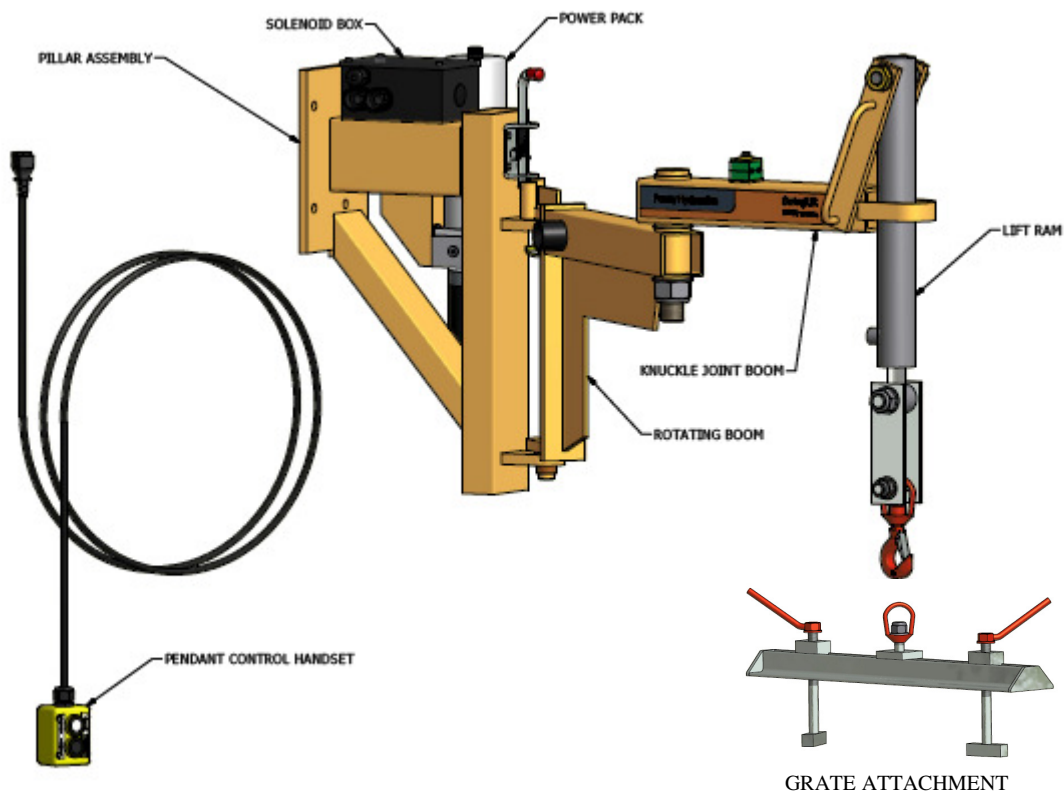





Due to our company's policy of continuous improvement, the following descriptions and illustrations used in this manual and parts book are without prejudice. We reserve the right to make alterations in order to increase the performance of our product, or for any other reason. We are not obliged to alter these instructions accordingly. These instructions do not assert to be complete



© This document is the property of Penny Hydraulics Limited and must not be copied or amended in part or in whole unless prior, express written permission is obtained from the Company

## GL250KJ SERIES

### Method of Operation.

1. Before operation, please read the operating instructions and ensure all persons involved in the lift are familiar with the equipment and local requirements. 
2. Check and ensure that the necessary documentation for the GL250KJ and Lifting attachments is valid and up to date.
3. Ensure the vehicle is on firm and level ground with the handbrake applied and wheel chocks deployed where necessary. 
4. Before operating check for potential hazards such as: overhead electric wires, nearby structures, public roads or paths, railways or rivers. Also pay attention to any underground services, eg. gas, electric, drainage etc. 
5. Check the unit visually for signs of defects or malfunction. 
6. Plug in the pendant control to the connector adjacent to the Grid Lift.
7. The lift is now ready for use.
8. Centralize and secure the lifting attachment to the grate or grid.
9. Release the boom retaining latches and manually position the lift ram over the load.
10. The pendant control functions are clearly marked on the hold to run buttons and can now be used as required.
11. Attach the load to the hook using suitable certified attachments only. 
12. Carefully manoeuvre the load into position and remain alert at all times.  
Keep clear of the suspended load as far as practically possible and do not try to physically restrain it if the balance suddenly changes.   
Do not leave the load suspended or attached whilst unattended. 
12. Do not drive the vehicle with a suspended load. 
13. On completion of the operation, ensure the GL250KJ is folded into the travelling position and all the locking devices firmly secured. 
14. Detach the pendant control and store in a secure lock up.

## Fault Finding

FAULT	CAUSE	REMEDY
No response when operating Raise / Lower buttons.	No power from battery.  Faulty earth connection.  Faulty or discharged vehicle battery	Check supply fuse and replace if necessary. Check all cable connections are clean and sound  Check, clean and secure all earth points.  Re charge or replace battery.
Ram will not lift.	Ram overloaded.	Remove excessive load.
Boom will not swivel freely.	Pivot mechanism seized.	Loosen, clean and reset.



## **Penny Hydraulics Limited Warranty Policy**

This Policy is intended to provide our customers with the best possible support to ensure trouble free use of their new Penny Hydraulics lifting equipment.

Products sold by the Company are guaranteed to be free from defective material and workmanship for a period of one year from the date of invoice or from the date of the commissioning certificate.

This warranty applies only under the following conditions:

- a) The unit or part must not have been subject to neglect or abuse, or operated under abnormal conditions or in an unapproved application.
- b) The responsibility of the Company is restricted to what is, in their judgement an adequate repair or replacement of the Company's product.
- c) An authorised engineer must carry out a six monthly inspection.
- d) The warranty is void if examination reveals that the unit or part has been repaired or adjusted other than by an authorised engineer.
- e) Normal service repairs carried out by authorised engineers are supported by their own warranty.
- f) Warranty does not extend to consumable items requiring replacement due to normal wear and tear.

Any claim under warranty must be made in the first instance by contacting Penny Hydraulics Ltd Service Department on 01246 811475 or via email at [service@pennyhydraulics.com](mailto:service@pennyhydraulics.com). The decision will then be made on how best to proceed after consultation with the customer.

### **UK Mainland**

We will normally have one of our own engineers based around the country visit the site to rectify the problem. This policy may be varied at our discretion but it is our aim to give the very best possible response to minimize product downtime and inconvenience.

### **Other Locations**

Warranty is limited to a parts only service but in certain areas we have service partners who may be able to assist. Any defective item should be returned to Penny Hydraulics Ltd for inspection and any valid warranty claim will include reasonable carriage costs both ways. A replacement part will then be sent to the customer.

No variation of the warranty as stated in the Company's Standard Terms and Conditions of Sale is authorised unless agreed in writing by a Director of the Company. This is the only warranty given and the Company accepts no other responsibility.

## Maintenance

Your **GridLift** GL250KJ series vehicle mounted crane is subject to the LIFTING OPERATIONS AND LIFTING EQUIPMENT (LOLER) regulations 1998 which is a statutory requirement to record on a formal document, the safe working condition of the crane, attachments and mounting structure.



Penny Hydraulics Ltd. Support Team offers a service package to meet customer requirements and conform to LOLER certification. Please see Service Contract form enclosed.

The following Planned Maintenance Schedule is designed to monitor the safe working order of the GL250KJ and includes a Thorough Examination by a Competent Person required by LOLER.

LOLER also requires that a Thorough Examination is carried out following any exceptional circumstance that may affect the safety of the equipment.

Any defects found whilst carrying out the Planned Maintenance Schedule must be reported and recorded and the equipment taken out of operation until action by a Competent Person is undertaken.

The Planned Maintenance Schedule may require the use of parts and consumables.

A list of recommended spares and lubricants is attached.

### Planned Maintenance Schedule

Before any work is undertaken, ensure the site supervisor is informed and that all safety precautions are observed and adhered to.

Pay attention to site specific safety and PPE requirements.

Unless dynamic checks, tests or setting up procedures are being carried out, always isolate the machine from the power supply.

Where dynamic checks are being performed, it is recommended that an assistant is designated to be on call if required.

Ensure a clean working area and sufficient cleaning materials.

Ensure the work area is cordoned off, paying particular attention to the sweep areas required for dynamic testing.

On receipt of a new machine and before it is put into service, check that there is no transit damage or evidence of mishandling.

Daily / Before Use.

- 1) Check visually for signs of external damage.
- 2) Check all guards are securely in place.
- 3) Check for loose or missing nuts, bolts and fasteners.
- 4) Check the lifting hook and connection to the link.
- 5) Check for damage to electrical cables and connectors

Weekly.

- 1) Check all as for Daily.
- 2) Thoroughly clean the support structure and check the security of the interface with the vehicle.

6 Monthly.

- 1) Check all as for Daily, Weekly and Monthly.
- 2) Thoroughly examine the main structures and sub frames for soundness and signs of deflection.
- 3) Thoroughly inspect all welds.
- 4) Thoroughly check the security of all fixings on the main body and sub frames.
- 5) Thoroughly examine all pivot points for excessive play. Remove the pivot pins and thoroughly inspect the condition of the pins and bushes and replace where necessary.
- 6) Thoroughly examine all electrical components, cables and connectors.

12 Monthly.

- 1) Check all as for Daily, Weekly, 3 Monthly and 6 Monthly.
- 2) Carry out a full load test as set out in the Load Test Procedure.
- 3) Carry out a statutory thorough examination as required by LOLER.

### **Load Test**

A load test must be carried out periodically to assess the integrity of the GL250KJ and its supporting structures.

Any defects or signs of potential failure must be rectified before the machine is allowed back into service.

### **Method**

- 1) Prepare the vehicle for operation in a safe working area and cordon off the area with appropriate barriers and work in progress signs.
- 2) Prepare the maximum prescribed test weights as determined by the GL250KJ model number.
- 3) Clear the site, admit power, connect the pendant control and rotate the GL250KJ in line with the axis of the chassis and the boom outboard.
- 4) Without load, manoeuvre the crane through all extents to ensure correct operation.
- 5) Lower the hook and attach it to the test weight prescribed.
- 6) Raise the load clear of the ground.
- 7) Check for signs of excessive flexing, structural deformation, paint flaking and excessive play in the joints.
- 8) Rotate the GL250KJ through its maximum swing and repeat the checks.
- 9) Return the weight to its starting position and detach.

On completion of the tests, restore the vehicle to its normal driving position, restore the working area and complete the necessary documentation.

## Overload Test

An overload test is carried out on all new GL250KJs at the factory and forms part of the test certificate requirements.

If the GL250KJ is fitted to the vehicle by Penny Hydraulics Ltd. or one of its authorized dealers, the system including the sub structure and vehicle interface will be Overload Tested as part of the test procedure.

An Overload Test must be carried out if:

- 1) The GL250KJ is fitted to a new or modified structure.
- 2) Any Modifications have been carried out to the GL250KJ or support structure.
- 3) Following any incident which may have caused damage to the GL250KJ or its supporting structure.

To carry out an Overload Test, elements of the system protection features have to be overridden and therefore must only be carried out by a competent person.



In severe or extreme conditions, it is recommended that an Overload Test is incorporated into the Annual Load Test of GL250KJ and its supporting structure

Please contact Penny Hydraulics Ltd. for further information.

## Service Contract

Date

<b>Lift location</b>	
<b>Contact Telephone</b>	<b>Post code</b>
	<b>Email</b>

<b>Invoice address</b>	
<b>Contact Telephone</b>	<b>Post code</b>
	<b>Email</b>

Penny Hydraulics Ltd agrees to carry out one annual service and one interim inspection on the lift in any twelve-month period. A test certificate will be left on site and a copy sent with the invoice.

In the event of a problem arising in-between scheduled visits the customer should telephone the Helpline on 01246 811475 as soon as possible so that appropriate action can be taken by us. There will be no charge for the call-out or for labour unless the problem is due to abuse or misuse. Parts may be added to the next invoice due.

The customer will be invoiced following each visit and by signing this document agrees to make full payment within 30 days of the invoice date in accordance with the agreed scale of charges, which may vary from time to time. This service contract will continue until cancelled in writing by either party.

Signed: ..... Print name: .....

Position: ..... Order number: .....

More details are available online.

Please fax, post or email this form to the office below.

Penny Hydraulics Ltd  
Tel 0044 (0) 1246 811475  
Fax 0044 (0) 1246 810403  
Email [service@pennyhydraulics.com](mailto:service@pennyhydraulics.com)  
Web [www.pennyhydraulics.com](http://www.pennyhydraulics.com)

## Technical Data

### General Dimensions / Loading Chart

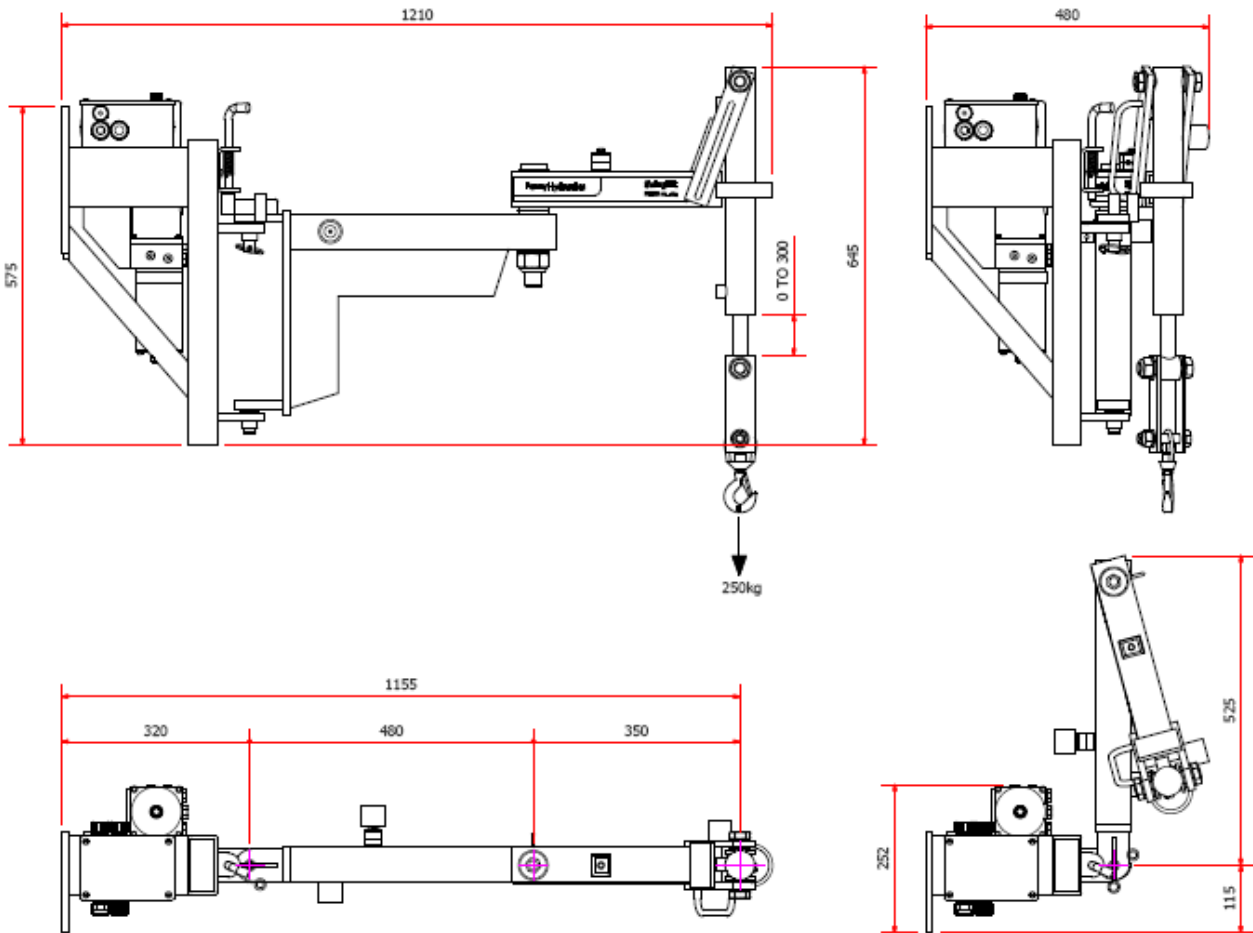

### Power Supply

Standard **GridLift** GL250KJs require a 24volt (12V Optional) DC electrical supply. Any circuit breakers employed in the system must be of a type that can cope with the surge of the electric motor.

### Electrical Specification

24 volts DC 40A  
12 volt optional

### Typical Weights

Standard **GridLift** GL250KJ 70kg subject to specification.

### Maximum Safe Working Load

Each **GridLift** GL250KJ is marked individually with its Maximum Working Load.

## **Noise Levels**

A survey sheet giving full details is available on request. Briefly, the results are as follows:

-

Power Pack 65dB(A)

These levels are well below those at which hearing can be damaged and below levels at which action is required under the noise at work regulations.

## **COSHH**

### **Terminal Disposal**

Penny Hydraulics will remove and dispose of the entire crane in an environmentally sound manner when required.

EC DECLARATION OF CONFORMITY

This declaration relates exclusively to the machinery in the state in which it was supplied, and excludes components, which are added, and/or operations carried out subsequently by the final user.

**We Penny Hydraulics Limited**  
Station Road Industrial Estate, Station Road, Clowne, S43 4AB.

Hereby declare that the product(s) listed below: -

---

Model: **GridLift Series**

---

Serial No.

---

Conforms to the essential requirements of 2008 / 1597, The Supply of Machinery (Safety) Regulations 2008 and the following Directives, Standards and other Normative Documents where appropriate.

EU Directives/Regulations	Machinery Directive 2006/42/EC Electrical Equipment (Safety) Regulations 1994 European Council EMC Directive 89/336/EEC
Standard(s)	BS EN 12999 Cranes, Loader Cranes, BS 7121 Parts 1,2 and 4 BS EN 982 Safety of Machinery EN 50081-1: 1997; Electromagnetic Compatibility, General Standard Radiated RF Emissions Class B (30MHz – 300MHz)
Normative Documents	DIN 15018 Steel Structures BS 2573 Rules for design The Lifting Operations and Lifting Equipment Regulations 1998. The Provision and Use of Work Equipment Regulations 1998.

---

All information is given within a Technical File compiled by: Mr Terry Brocklehurst  
c/o Penny Hydraulics Ltd.

---

---

Place: - Penny Hydraulics Limited	Signature: - 
Date: -	Full Name: - J. D. Penny
	Position: - M.D.



---

BS EN ISO 9001: 2000 British Standards Institute Registered Company  
Certificate No. FM 20203

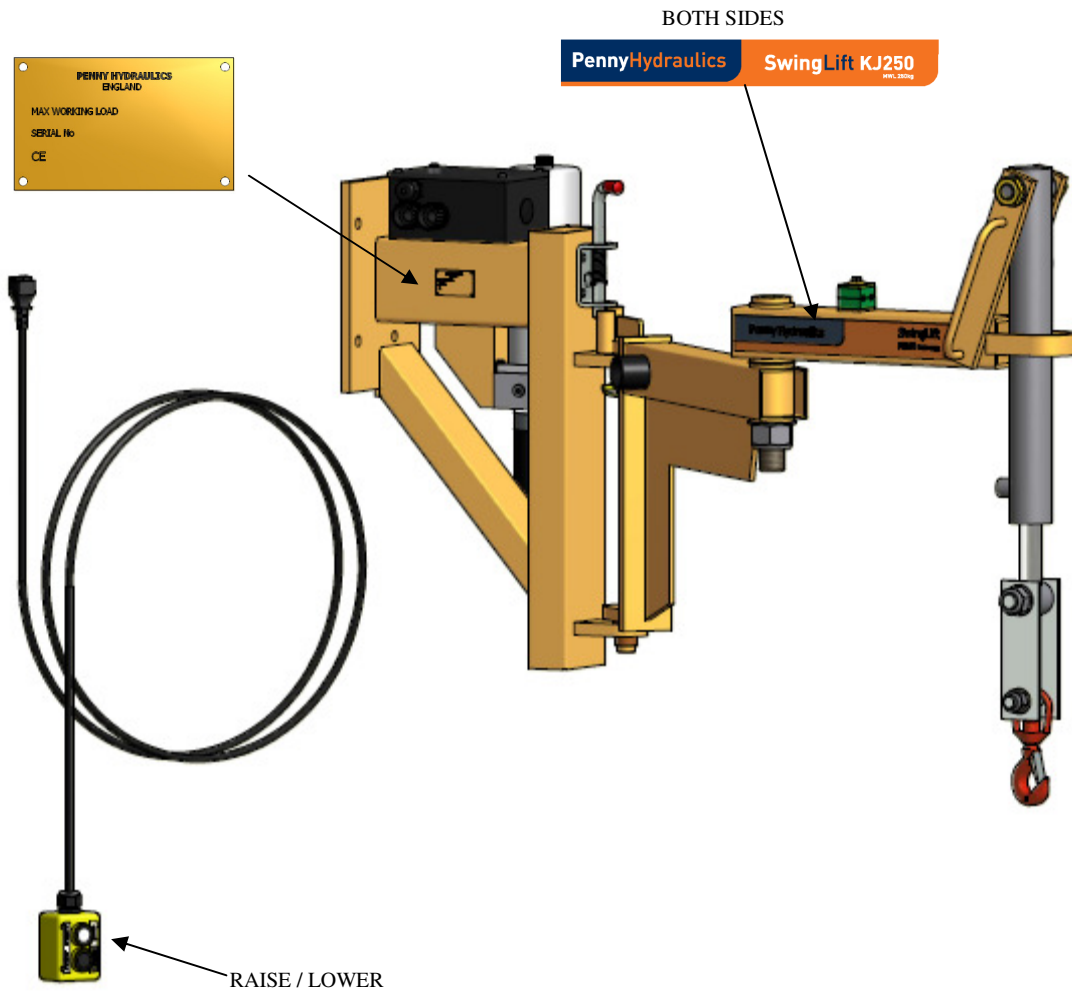

## Signs



-  Read The Manual
-  Refer To The Manual
-  Caution

## Lubricants

DUTY	LUBRICANT	SPECIFICATION
Power Pack	Mineral Oil - Hydraulic	HM32
General Lubrication	Grease	LEP2

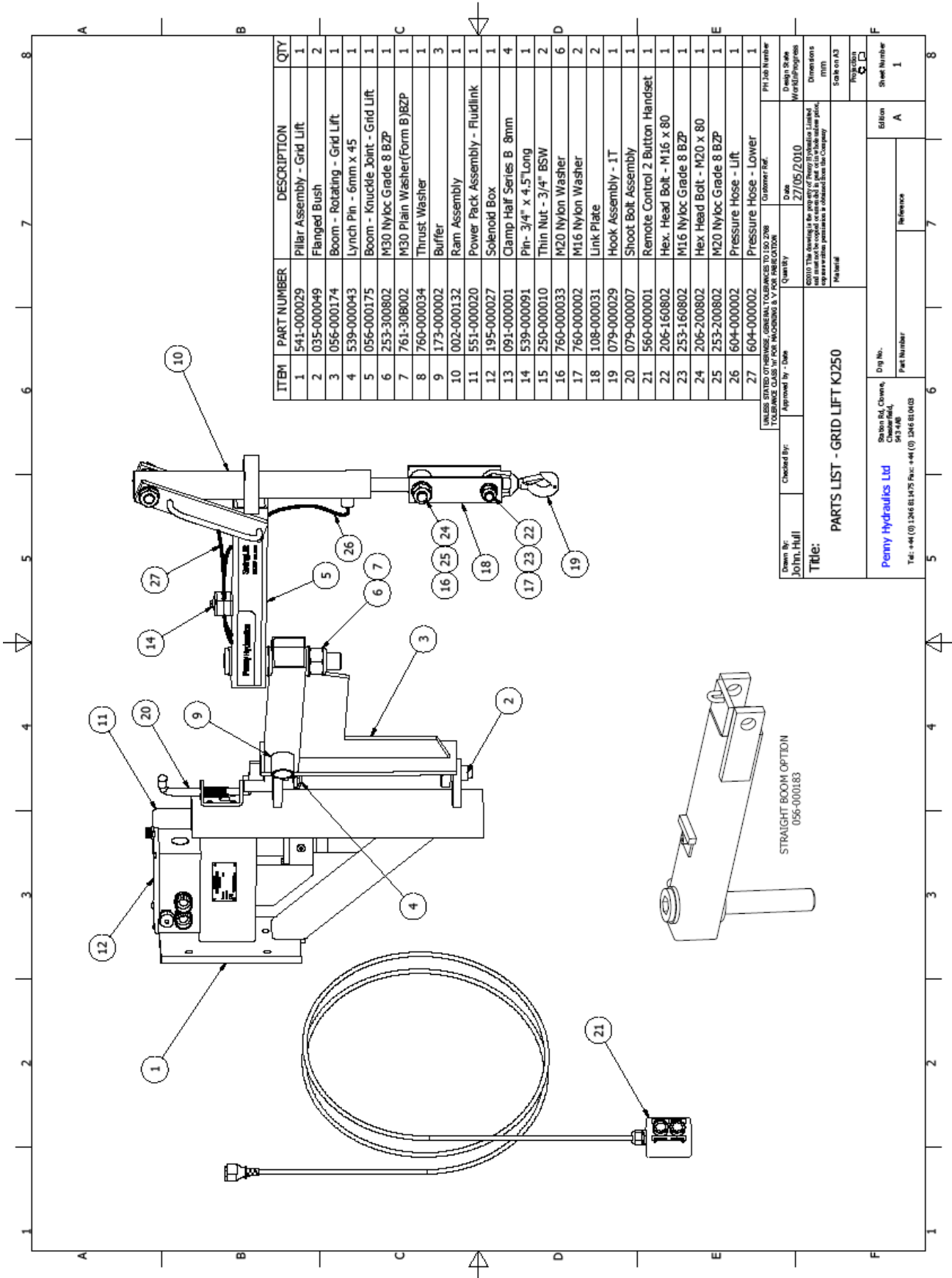

ITEM	PART NUMBER	DESCRIPTION	QTY
1	541-000029	Pillar Assembly - Grid Lift	1
2	035-000049	Flanged Bush	2
3	056-000174	Boom - Rotating - Grid Lift	1
4	539-000043	Lynch Pin - 6mm x 45	1
5	056-000175	Boom - Knuckle Joint - Grid Lift	1
6	253-300802	M30 Nyloc Grade 8 BZP	1
7	761-308002	M30 Plain Washer(Form B)BZP	1
8	760-000034	Thrust Washer	1
9	173-000002	Buffer	3
10	002-000132	Ram Assembly	1
11	551-000020	Power Pack Assembly - Fluidlink	1
12	195-000027	Solenoid Box	1
13	091-000001	Clamp Half Series B 8mm	4
14	539-000091	Pin - 3/4" x 4.5" Long	1
15	250-000010	Thin Nut - 3/4" BSW	2
16	760-000033	M20 Nylon Washer	6
17	760-000002	M16 Nylon Washer	2
18	108-000031	Link Plate	2
19	079-000029	Hook Assembly - 1T	1
20	079-000007	Shoot Bolt Assembly	1
21	560-000001	Remote Control 2 Button Handset	1
22	206-160802	Hex. Head Bolt - M16 x 80	1
23	253-160802	M16 Nyloc Grade 8 BZP	1
24	206-200802	Hex Head Bolt - M20 x 80	1
25	253-200802	M20 Nyloc Grade 8 BZP	1
26	604-000002	Pressure Hose - Lift	1
27	604-000002	Pressure Hose - Lower	1

Drawn By: John Hull	Checked By:	Quantity:	Date: 27/05/2010
Title: <b>PARTS LIST - GRID LIFT KJ250</b>		PH Job Number:	Customer Ref:
Penny Hydraulics Ltd Station Rd, Clonsilla, Chester Rd, 543 4AB Tel: +44 (0) 1246 813475 Fax: +44 (0) 1246 810403		© 2010 This drawing is the property of Penny Hydraulics Limited and must not be copied or amended in any way without the written approval of Penny Hydraulics Limited. All dimensions are in millimeters unless stated otherwise.	
Dwg No.:	Revision:	Drawn By:	Drawn Date:
Part Number:	Reference:	Drawn By:	Drawn Date:
Sheet Number:	Revision:	Drawn By:	Drawn Date:
1	A	Drawn By:	Drawn Date:

## Electrical Schematic

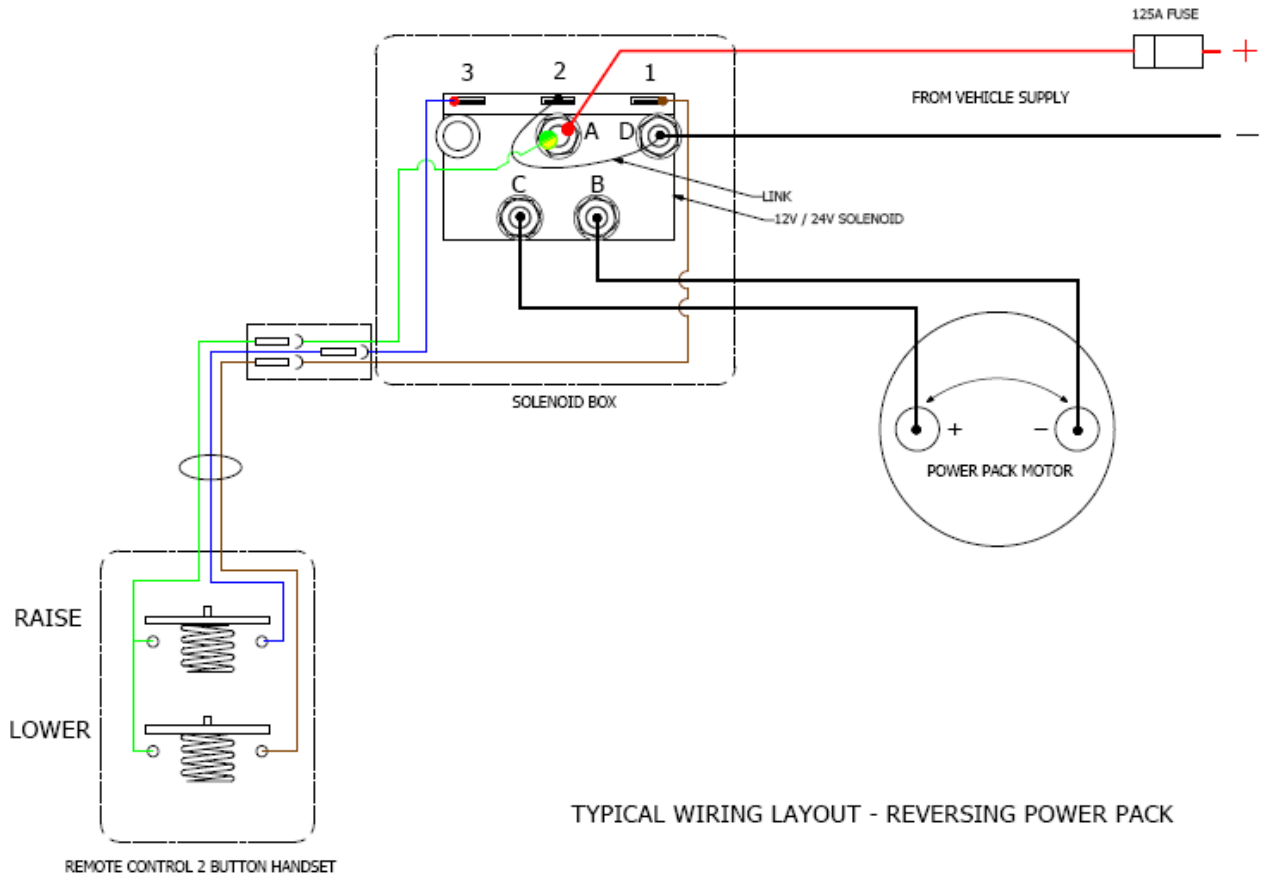

## Grate Attachment

Part No. 031-000001

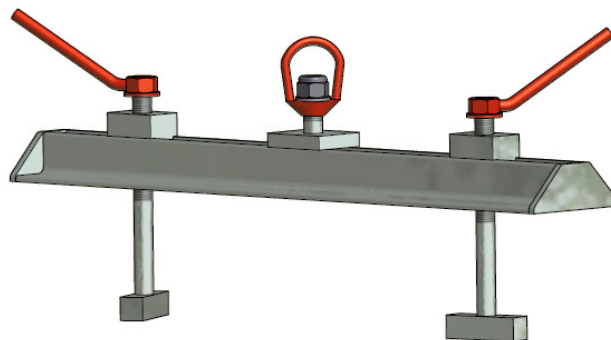





## Service

Current legislation requires that each item of lifting equipment be thoroughly examined at least once in every 12 month period by a competent person. Our service contract will ensure continued, safe, reliable use of the equipment and full compliance with current legislation.

Key benefits of a Penny Hydraulics service contract include...

- **Combined maintenance and statutory inspection saves time and money**
- **Nationwide coverage**
- **Statutory inspections completed**
- **OEM spares available ex-stock**
- **High first time fix rate**
- **Reduced vehicle downtime**

## Training

The latest health & safety legislation requires that all employers ensure all people using or supervising the use of work equipment have received adequate training in method, risk and precautions.

Penny Hydraulics offer nationwide training by qualified instructors for their comprehensive range of lifting equipment. Training includes practical and theoretical input from the delegates with a certificate of competence issued on successful completion of the course.



**Penny Hydraulics Limited**

**Station Road | Clowne | Chesterfield | Derbyshire | S43 4AB**

**t +44 (0) 1246 811475 | f +44 (0) 1246 810403**

**e [sales@pennyhydraulics.com](mailto:sales@pennyhydraulics.com) | w [pennyhydraulics.com](http://pennyhydraulics.com)**

This document and all designs, images, words, logos and products contained therein are the property of Penny Hydraulics Limited and must not be copied or amended in part or in whole unless prior, express written permission is obtained from the Company. © Penny Hydraulics Limited 2012.