

PH330.4

TECHNICAL DATA	PH330.4
Lifting capacity	32kNm
Max. lifting height from crane base	6400mm
Max. working slope	5°
Max. working pressure	220bar
Suggested oil flow	10-12l per min.
Electro-hydraulic power unit supply voltage	12V/24V
Max. absorption electro-hydraulic power unit (12V)	260A
Max. absorption electro-hydraulic power unit (24V)	160A
Hydraulic oil tank capacity (H version)	15l
Hydraulic oil tank capacity (electric version)	11l

CRANE WEIGHTS	kg
PH330.4	325-345
Base with extendable stabilisers	130-140

DIMENSIONS

CRANE	A	B1	B2
PH 330.4	1570	930	970

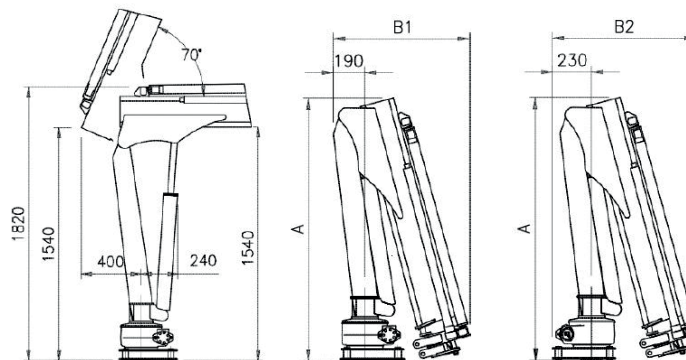

330.4	mm	kg	*
	1430	2200	990
	2430	1300	990
	3430	900	900
	4430	700	700
	5360	550	550
	6360	420	420

Hydraulic extension
 Standard manual extension
 Optional manual extension
 * "D" version



Penny Hydraulics Limited

Station Road | Clowne | Chesterfield | Derbyshire | S43 4AB | United Kingdom
 t +44 (0) 1246 811475 | f +44 (0) 1246 810403

w www.pennyhydraulics.com | e sales@pennyhydraulics.com