

# PH330.3

| TECHNICAL DATA                                     | PH330.3         |
|--|-----------------|
| Lifting capacity                                   | 32kNm           |
| Max. lifting height from crane base                | 5500mm          |
| Max. working slope                                 | 5°              |
| Max. working pressure                              | 220bar          |
| Suggested oil flow                                 | 10-12l per min. |
| Electro-hydraulic power unit supply voltage        | 12V/24V         |
| Max. absorption electro-hydraulic power unit (12V) | 260A            |
| Max. absorption electro-hydraulic power unit (24V) | 160A            |
| Hydraulic oil tank capacity (H version)            | 15l             |
| Hydraulic oil tank capacity (electric version)     | 11l             |

| CRANE WEIGHTS                    | kg      |
|----------------------------------|---------|
| PH330.3                          | 295-315 |
| Base with extendable stabilisers | 130-140 |

## DIMENSIONS

| CRANE    | A    | B1  | B2  |
|----------|------|-----|-----|
| PH 330.3 | 1550 | 820 | 860 |

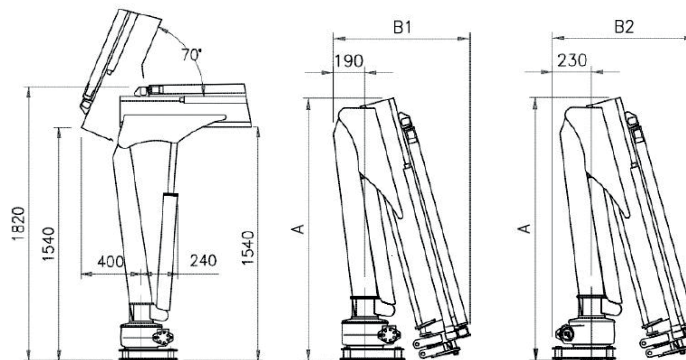

| 330.3 | C    | D    |
|-------|------|------|
| mm    | 1360 | 2360 |
| kg    | 2350 | 1350 |
| *     | 990  | 990  |

Hydraulic extension
  Standard manual extension
  Optional manual extension
 \* "D" version



Penny Hydraulics Limited

Station Road | Clowne | Chesterfield | Derbyshire | S43 4AB | United Kingdom  
 t +44 (0) 1246 811475 | f +44 (0) 1246 810403

w [www.pennyhydraulics.com](http://www.pennyhydraulics.com) | e [sales@pennyhydraulics.com](mailto:sales@pennyhydraulics.com)