

PH330.2

TECHNICAL DATA	PH330.2
Lifting capacity	32kNm
Max. lifting height from crane base	4500mm
Max. working slope	5°
Max. working pressure	220bar
Suggested oil flow	10-12l per min.
Electro-hydraulic power unit supply voltage	12V/24V
Max. absorption electro-hydraulic power unit (12V)	260A
Max. absorption electro-hydraulic power unit (24V)	160A
Hydraulic oil tank capacity (H version)	15l
Hydraulic oil tank capacity (electric version)	11l

CRANE WEIGHTS	kg
PH330.2	270-290
Base with extendable stabilisers	130-140

DIMENSIONS

CRANE	A	B1	B2
PH 330.2	1550	820	860

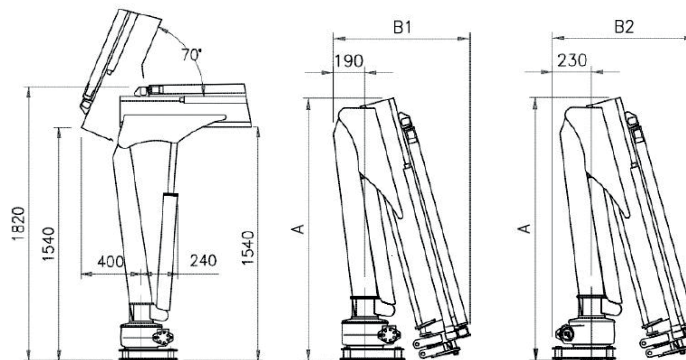

330.2	B		C		D	
mm	1300	2300	3300	4360	5360	6360
kg	2500	1400	1000	700	550	420
*	990	990	990	700	550	420

Hydraulic extension
 Standard manual extension
 Optional manual extension
 * "D" version



Penny Hydraulics Limited

Station Road | Clowne | Chesterfield | Derbyshire | S43 4AB | United Kingdom
 t +44 (0) 1246 811475 | f +44 (0) 1246 810403

w www.pennyhydraulics.com | e sales@pennyhydraulics.com