

PH270L.2



TECHNICAL DATA	PH270L.2
Lifting capacity	22kNm
Max. lifting height from crane base	4800mm
Max. working slope	5°
Max. working pressure	220bar
Suggested oil flow	10-12l per min.
Electro-hydraulic power unit supply voltage	12V/24V
Max. absorption electro-hydraulic power unit (12V)	240A
Max. absorption electro-hydraulic power unit (24V)	150A
Hydraulic oil tank capacity (H version)	15l
Hydraulic oil tank capacity (electric version)	11l

CRANE WEIGHTS	kg
PH270L.2	235-255
Base with extendable stabilisers	102-109
Beam with 2 extendable stabilisers	69-83

DIMENSIONS

CRANE	A	B1	B2
PH 270L.2	1510	1130	1150

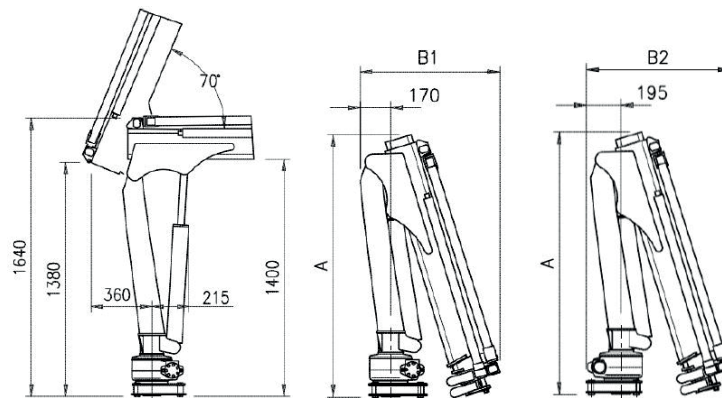

270L.2	B		C		
mm	1400	2600	3800	5000	6000
kg	1870	1000	680	500	350
*	990	990	680	500	350

Hydraulic extension
 Standard manual extension
 B/C/D Optional manual extension
 * "D" version



Penny Hydraulics Limited

Station Road | Clowne | Chesterfield | Derbyshire | S43 4AB | United Kingdom
 t +44 (0) 1246 811475 | f +44 (0) 1246 810403

w www.pennyhydraulics.com | e sales@pennyhydraulics.com